

PEDESTAL CANTILEVER



Este sistema ha sido diseñado para proporcionar una solución para ascensores de foso reducido. Cumple con los requisitos de las normas EN81-20 y EN81-21.

Su diseño especial permite al instalador del ascensor colocarlo en diferentes lugares del foso, inclusive entre las guías del contrapeso, necesitando solamente un punto de impacto para el amortiguador durante la operación nominal y de mantenimiento.

This pedestal has been designed to provide a solution for small pit elevators. It meets with the requirements of the **EN81-21** and **EN81-20**.

Its particular design allows the elevator installer to locate it in different areas of the pit, even between the counterweight guides, and it only requires the elevator to have one area for impact of the buffer during both regular and maintenance operations.



Max. load: 1m/s, 2500 kg

PEDESTAL CANTILEVER

Cómo hacer un pedido / How to order:

Type	A	B	BN
C100	550	225	2

Mod.	A (mm)	B (mm)	BN	Safety Switch
C100	500-1000	85-500	chart #1	2 x 2NC: Schmersal AZ17-02ZK

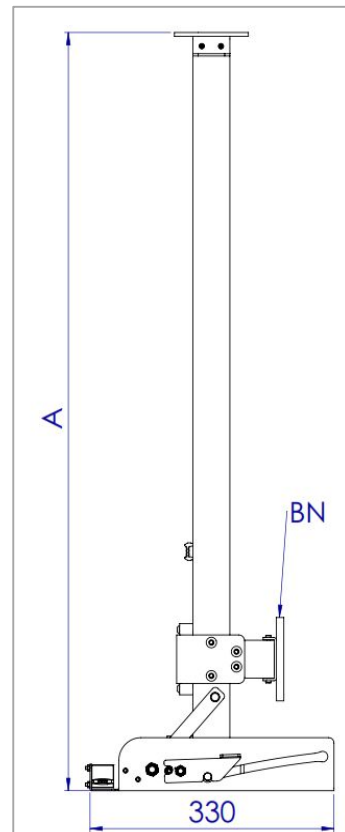
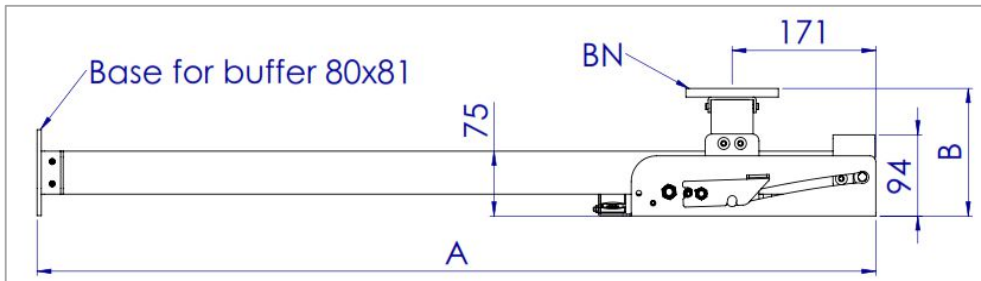
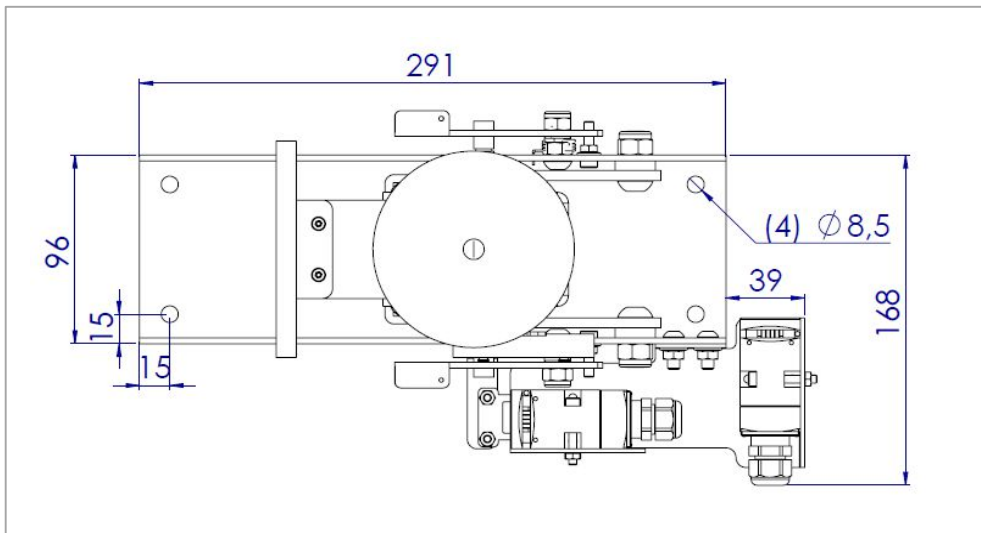

CHART #1	Ø Buffer	H Buffer	Code to order BN
How to choose the Buffer Base for Maintenance or Nominal buffers. Como elegir la Base de Buffer para buffer nominal o de mantenimiento	none		0
	80	81	1
	101	80	2
	167	81	3

